



TC 12E-22E



tritacarne meat grinders

- Costruzione in alluminio pressofuso lucidato.
- Motore ventilato.
- Riduttore tritacarne a bagno d'olio.
- Bocca ed elica tritacarne in ghisa trattata per uso alimentare, su richiesta anche in acciaio inox Aisi 304.
- Piastra e coltello inox.

Versione CE con:

- Comandi IP54 con NVR.
- Opzioni:
- Comandi con inversione.

- Made from diecasted polished aluminium.
- Ventilated motor.
- Oil-bath gear box
- Cast iron head and feeding worm.
(Aisi 304 stainless steel on demand).
- S/S plates and knives.

CE version:

- 24 volt controls and NVR device
- Optional:
- Reverse

TC 12E - 22E

Optionals



1. Tagliacarote
Carrots cutter



2. Tagliapatate "cips" e funghi
Potatoes "cips" cutter



3. Tagliamozzarella
Mozzarella cutter



4. Passapomodoro per TC/TCG 12E
Tomato sauce making for TC/TCG 12E



5. Passapomodoro per TC/TCG 22E
Tomato sauce making for TC/TCG 22E

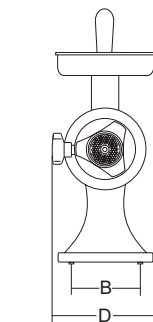
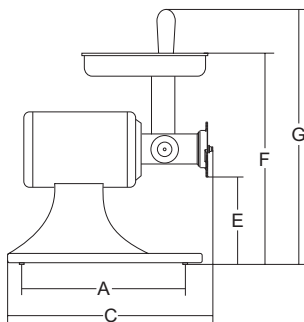

Potenza
Power
Spamung
Puissance

Alimentazione
Power source
Betriebsspannung
Alimentation

Prod. oraria
Output/h.
Leistung/h.
Débit/h.

Piastra in dotazione
Standard Plate
Scheibe
Filletes

A B C D E F G

Peso netto
Net weight
Nettogewicht
Poids net

Dimensioni imballo
Shipping
Verpack. abmessungen
Dim. emballage

Peso lordo
Gross weight
Bruttogewicht
Poids brut

	watt/HP	Kg/10 min.	ø mm	mm	mm	mm	mm	mm	mm	mm	Kg	mm	kg	
TC 12E	735/1	230-400V/50Hz	25	4,5	225	185	430	215	140	445	520	18	320x460x470	20
TC 22E	800/1,2	230-400V/50Hz	33	4,5	225	185	440	215	135	445	520	21	320x460x470	23

Potencia
Potência
Мощность
功率

Alimentación
Alimentação
Питание
電源

Producción horaria TC
TC Product/h
Часовая производительность TC
TC 产 量/时

Placa en dotación
Lâmina em dotação
标配刀盘

A B C D E F G

Peso netto
Pésó líquido
Бес нетто
净重

Dimensiones embalaje
Dimensões embalagem
Размеры упаковки
包装尺寸

Peso bruto
Pésó bruto
Бес опры
毛重